

New energy · New world

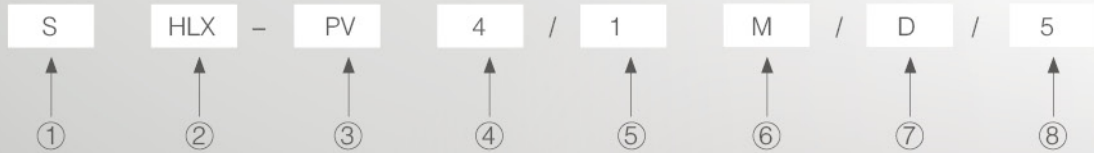

DC COMBINER BOX TYPE



① Suntree electric

② Product model (combiner box)

③ PV

④ Input channel (1-24)

⑤ No. of output channel of MPPT

⑥ Monitoring unit

⑦ Diode

⑧ DC550V/DC1000V



SHLX-PV1/1 DC COMBINER BOX

- High reliability
 - With DC FUSE
 - With DC Surge Protection Device
 - With DC circuit breaker or DC load isolation switch.
- Strong adaptability
 - IP65 design, waterproof, anti dust and anti ultraviolet.
 - Strict test for high and low temperature, used widely.
 - The simple installation, the simplified system wiring, the convenient wiring .
 - The box body is made of cold rolled steel and other metal materials.
- Flexible configuration
 - Used for single crystal silicon solar modules, polycrystalline silicon solar modules, thin film solar modules. Current rating of the photovoltaic fuse, circuit breaker, load isolation switch is modified.

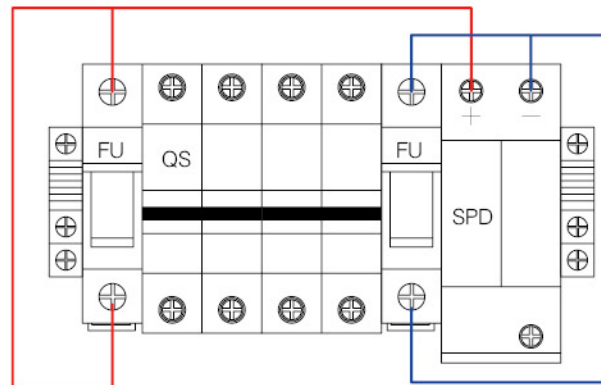

DC550V

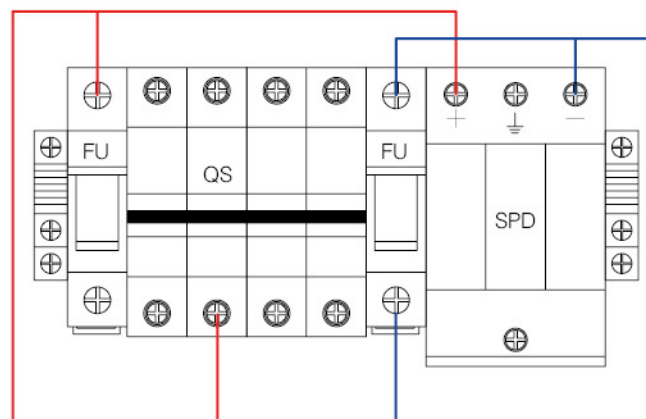

DC1000V

DESCRIPTION

SHLX-PV1/1 combiner box is suitable for inverter (MAX input voltage DC550V/DC1000V, 1 PV input channel, 1 output channel, single MPPT inverter). Box body is made of PVC engineering materials, with test for fire retardant, temperature rise, anti impact, anti ultraviolet, and other testing. IP65 protection grade.

TECHNICAL PARAMETERS

Name		SHLX-PV1/1	
Electric parameter			
System maximum dc voltage	550		1000
Maximum input current for each string		15A	
Maximum input strings		1	
Maximum output switch current		16A/20A	
Number of inverter MPPT		1	
Number of Output strings		1	
Lightning protection			
Category of test		II grade protection	
Nominal discharge current		20kA	
Maximum discharge current		40kA	
Voltage protection level	2.8kV		3.8kV
Maximum continuous operating voltage U _c	630V		1050V
Poles	2P		3P
Structure characteristic		Plug-push module	
System			
Protection grade		IP65	
Output switch		DC isolation switch(standard)/DC circuit breaker(optional)	
SMC4 Waterproof Connectors		Standard	
PV dc fuse		Standard	
PV surge protector		Standard	
Monitoring module		Optional	
Preventing diode		Optional	
Box material		PVC	
Installation method		Wall mounting type	
Operating Temperature		-25°C~ +55°C	
Elevation of temperature		2000M	
Permissible relative humidity		0-95% , no condensation	
Mechanical parameter			
Width×High×Depth		300×260×140	

SCHEMATIC DIAGRAM

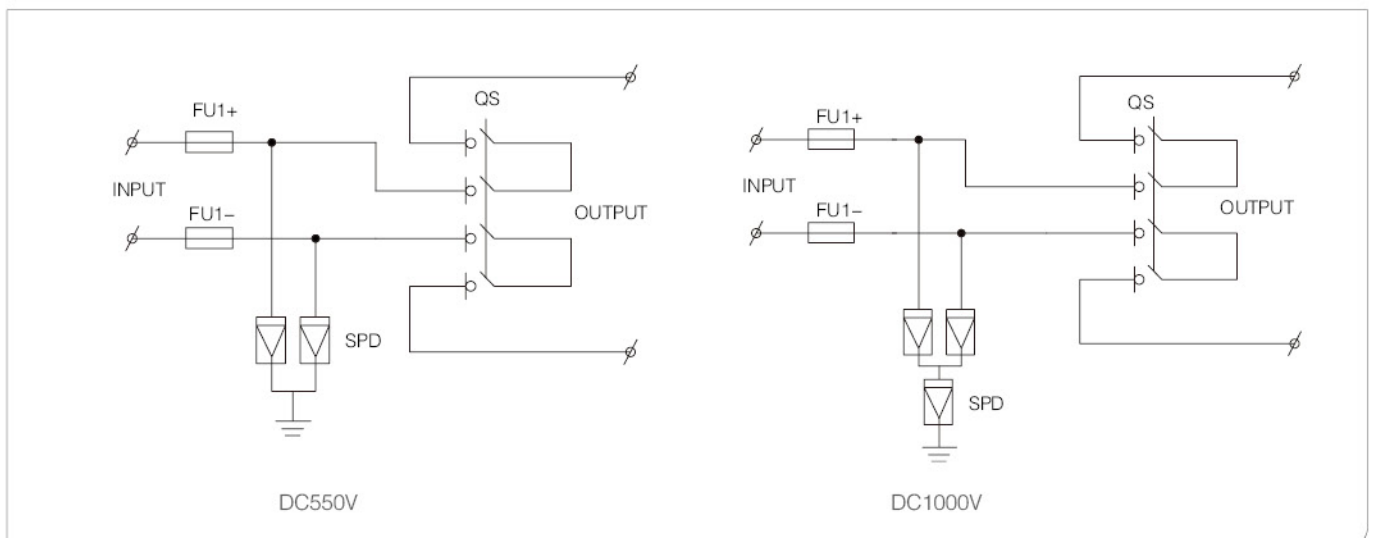

SHLX-PV2/1 DC COMBINER BOX

- High reliability
 - With DC FUSE
 - With DC Surge Protection Device
 - With DC circuit breaker or DC load isolation switch.
- Strong adaptability
 - IP65 design, waterproof, anti dust and anti ultraviolet.
 - Strict test for high and low temperature, used widely.
 - The simple installation, the simplified system wiring, the convenient wiring .
 - The box body is made of cold rolled steel and other metal materials.
- Flexible configuration
 - Used for single crystal silicon solar modules, polycrystalline silicon solar modules, thin film solar modules. Current rating of the photovoltaic fuse, circuit breaker, load isolation switch is modified.

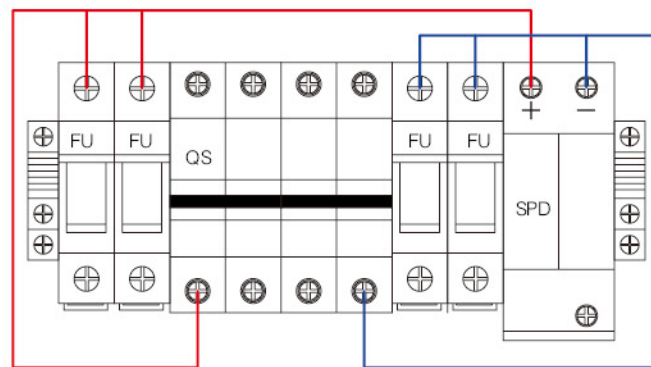

DC550V

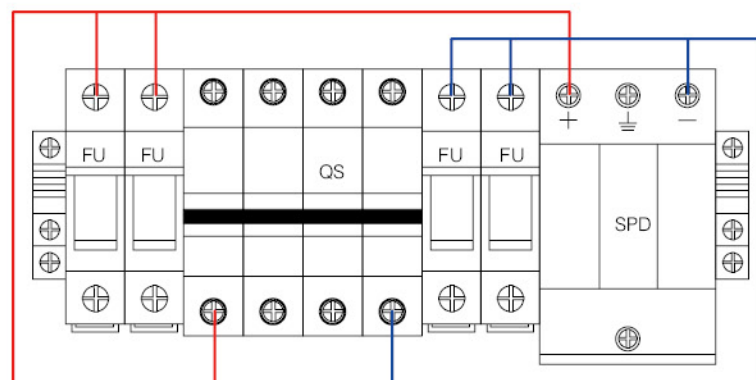

DC1000V

DESCRIPTION

SHLX-PV2/1 combiner box is suitable for inverter (MAX input voltage DC550V/DC1000V, 2 PV input channel, 1 output channel, single MPPT inverter). Box body is made of PVC engineering materials, with test for fire retardant, temperature rise, anti impact, anti ultraviolet, and other testing. IP65 protection grade.

Design and configuration strictly accordance with the "Technical specification for photovoltaic junction equipment " CGC/GF 037:2014.

TECHNICAL PARAMETERS

Name	SHLX-PV2/1	
	Electric parameter	
System maximum dc voltage	550	1000
Maximum input current for each string	15A	
Maximum input strings	1	
Maximum output switch current	20A/32A	
Number of inverter MPPT	1	
Number of Output strings	1	
	Lightning protection	
Category of test	II grade protection	
Nominal discharge current	20kA	
Maximum discharge current	40kA	
Voltage protection level	2.8kV	3.8kV
Maximum continuous operating voltage U _c	630V	1050V
Poles	2P	3P
Structure characteristic	Plug-push module	
	System	
Protection grade	IP65	
Output switch	DC isolation switch(standard)/DC circuit breaker(optional)	
SMC4 Waterproof Connectors	Standard	
PV dc fuse	Standard	
PV surge protector	Standard	
Monitoring module	Optional	
Preventing diode	Optional	
Box material	PVC	
Installation method	Wall mounting type	
Operating Temperature	-25°C~ +55°C	
Elevation of temperature	2000M	
Permissible relative humidity	0-95% , no condensation	
	Mechanical parameter	
Width×High×Depth	300×260×140	

SCHEMATIC DIAGRAM

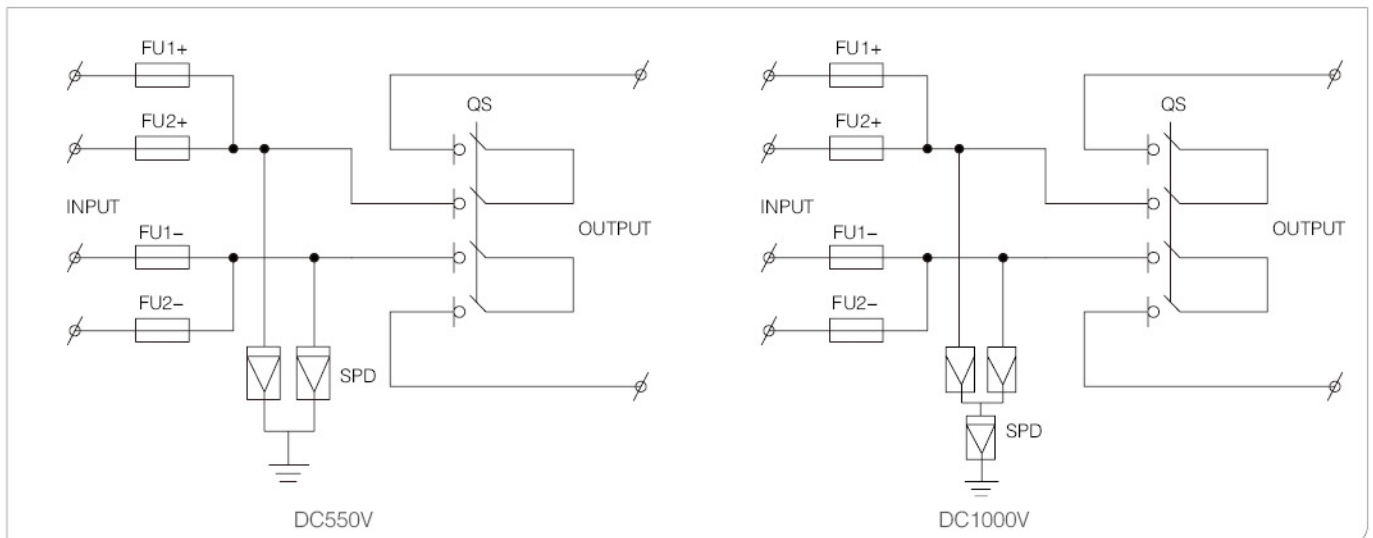

SHLX-PV4/1 DC COMBINER BOX

- High reliability
 - With DC FUSE
 - With DC Surge Protection Device
 - With DC circuit breaker or DC load isolation switch.
- Strong adaptability
 - IP65 design, waterproof, anti dust and anti ultraviolet.
 - Strict test for high and low temperature, used widely.
 - The simple installation, the simplified system wiring, the convenient wiring .
 - The box body is made of cold rolled steel and other metal materials.
- Flexible configuration
 - Used for single crystal silicon solar modules, polycrystalline silicon solar modules, thin film solar modules. Current rating of the photovoltaic fuse, circuit breaker, load isolation switch is modified.

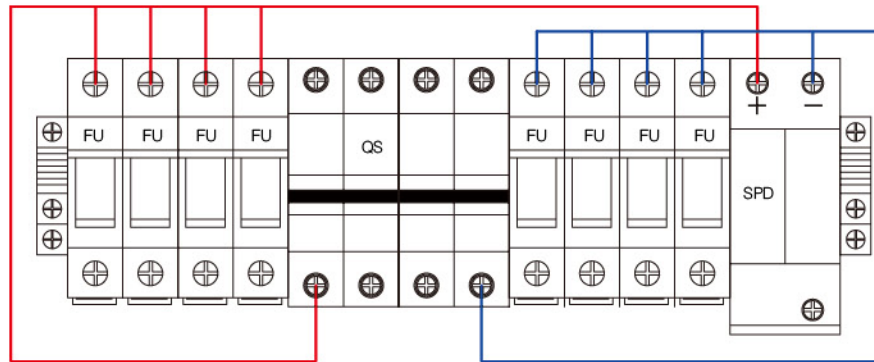

DC550V

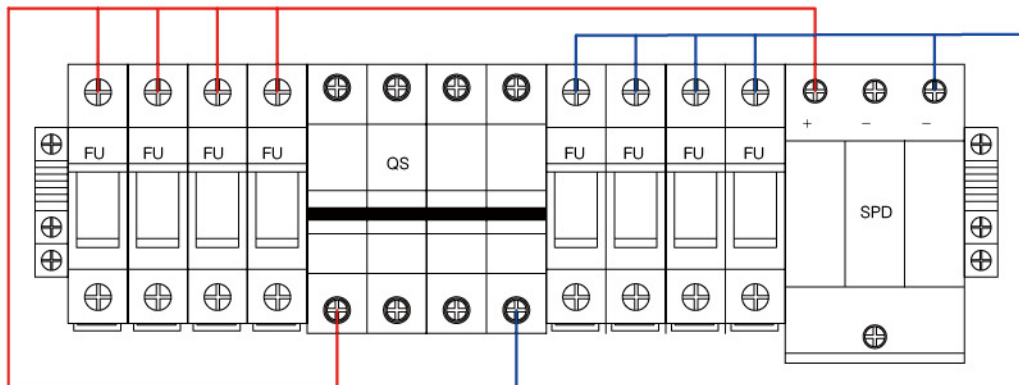

DC1000V

DESCRIPTION

SHLX-PV4/1 combiner box is suitable for inverter (MAX input voltage DC550V/DC1000V, 4 PV input channel, 1 output channel, single MPPT inverter). Box body is made of PVC engineering materials, with test for fire retardant, temperature rise, anti impact, anti ultraviolet, and other testing. IP65 protection grade.

Design and configuration strictly accordance with the "Technical specification for photovoltaic junction equipment " CGC/GF 037:2014.